

# DTS 3300 (direct replacement for DTS 2302)

The DTS 3300, a larger cantilever spindle, is also primarily intended for tracing forms into grinding wheels. When used in tracing applications, this model may accommodate diamond rolls up to 6 inches (150 mm) in diameter and ½ inch (13 mm) wide. Because the DTS 3300 features a larger shaft and bearings than the DTS 1300, it is sometimes used to plunge forms into grinding wheels, up to about 1½ inches (40 mm) wide.

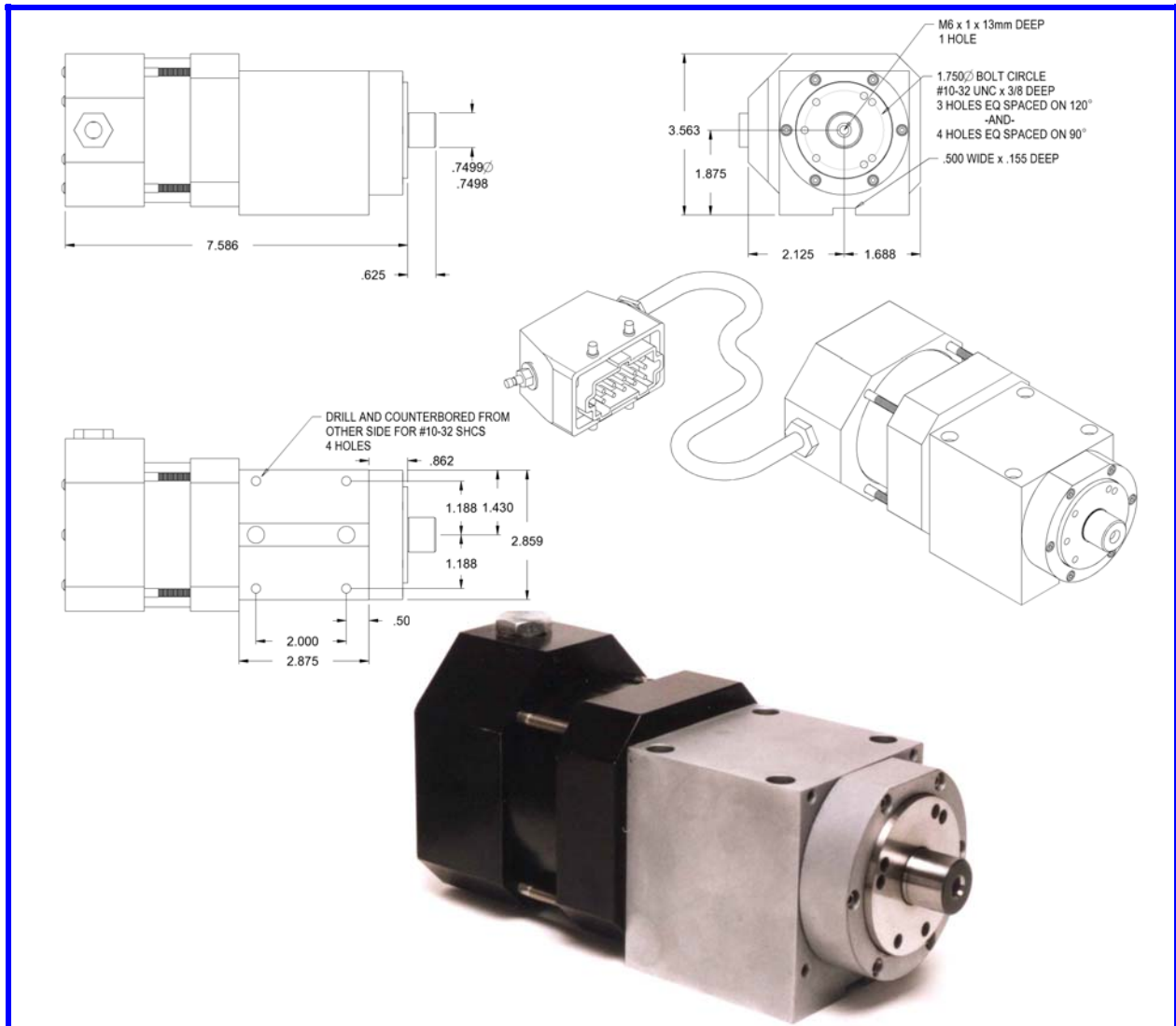

**G II Solutions, Inc.**  
 201 Bank Street  
 P.O. Box 428  
 Central, SC 29630

Phone: 864.639.6605  
 Fax: 864.639.4056  
 E-mail: [info@giisolutions.com](mailto:info@giisolutions.com)  
 Web Site: [www.giisolutions.com](http://www.giisolutions.com)